

# Crystals and Crystallization

Bio5325

Spring 2006

# Crystal Vocabulary

**Mosaicity** (mosaic spread) –Protein crystals are imperfect, consisting of a mosaic of domains that are slightly misaligned. As a result, diffracted rays are emitted as cones rather than perfectly linear beams.

**Habit** –the outward appearance of a crystal. Can be indicative of crystallographic symmetry.

**Mother liquor** –growth medium for a crystal. The crystal is harvested from the mother liquor and stabilized in a harvest buffer.

**Twinned** –crystal disorder in which multiple lattices are joined together. Merohedral twinning results in exact superposition of reflections from multiple lattices (consider the case of a crystal with a slice of volume that is flipped 180 deg. with respect to the host crystal). T. O. Yeates, *Methods Enzymol.* **276**, 344-358, 1997.

# Properties of Protein Crystals

Solvent content of >60-70% is typical for protein crystals, resulting in large solvent channels that permit diffusion of substrates, heavy atoms, etc.

Crystal packing interactions involve a small fraction of the protein surface area. Crystal packing can change during equilibration in harvest buffers, resulting in nonisomorphism, and significantly better/worse diffraction than starting condition.

Protein crystals are fragile and do not survive the crush test.

Can be stained with vital dyes (Hampton "izit" dye). "Is it a protein crystal?"

# Crystal Growth

Growth from supersaturated protein solution.

Nucleation phase precedes crystal growth.

Crystal growth can be seeded from a tiny crystalline fragment.

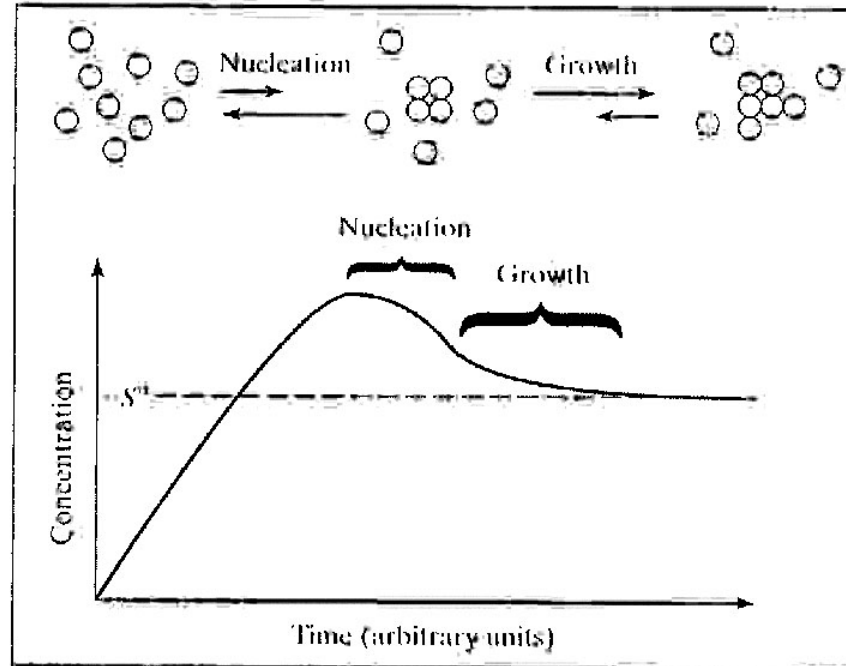

# Growing Protein Crystals

## Methods

- Vapor diffusion
- Dialysis
- Protein droplet under oil

## Sample Requirements

- Purity (more is usually better)
- Amount of protein ( $\geq 1$  mg. of pure protein)

## Resources/Strategies

- Buy a crystallization kit:

<http://www.hamptonresearch.com/>

<http://www.nextalbiotech.com/>

- Let someone else do the experiment:

<http://www.decode.com/Services/Structural-Biology.php>

<http://www.hwi.buffalo.edu/Research/Facilities/CrystalGrowt.html>

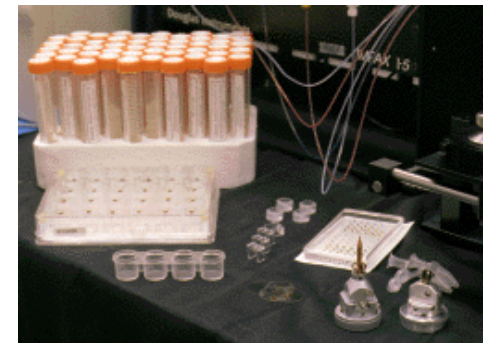
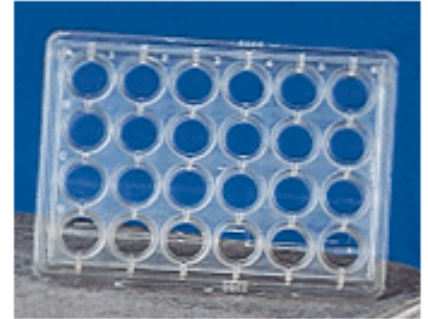
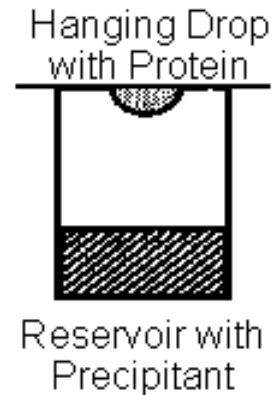

# Crystal Gallery

cryoloop (~0.5mm dia.)

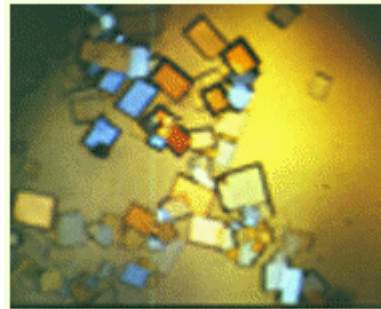
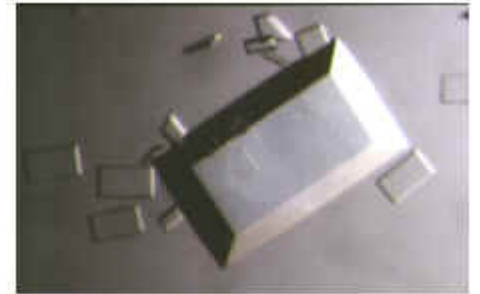
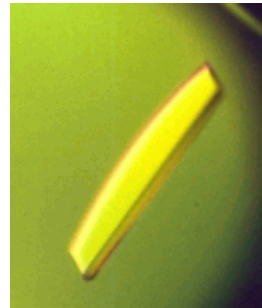

# Harvesting Crystals

Harvest solution is typically a more precipitating condition than the crystal growth solution.

Crystal is plucked from an equilibrium growth condition into a protein-free solution where it can dissolve.

Osmotic shock (too much PEG, salt, etc) can crack the crystal. May require step-wise equilibration to safely achieve the final harvest condition.

Often begin by using the reservoir solution for harvest.

Harvest condition must be optimized empirically (like crystal growth condition) to avoid damaging the crystal while achieving a reproducible (isomorphous) end point.

# Radiation-induced Damage

X-ray exposure damages proteins, resulting in a progressive decline in diffraction quality (decreased diffraction intensity, increased mosaicity, streaking, etc.).

Different crystals show large variations in radiation sensitivity.

The damage is time-dependent and is probably caused by oxygen-based free radicals.

Shorter exposures with high intensity (synchrotron-based) radiation will generally improve the situation.

Freezing crystals will slow radiation-induced damage process. Typically required for data collection at modern synchrotron light sources.



# Freezing Crystals

Procedures originally developed for cryo-electron microscopy. Rapid dunking in liquid helium, nitrogen, or propane.

Goal is to prevent crystalline ice formation during freezing (which diffracts strongly and damages the crystal).

Frozen crystal is suspended in vitreous ice, a glassy solid.

Cryoprotectants (glycerol, ethylene glycol, sucrose) added to harvest condition to prevent ice formation. Too much will damage the crystal before it is frozen.

Frozen crystals can be stored for years in liquid nitrogen. Data collection in gaseous nitrogen stream ( $\sim -165$  °C).

# The Crystallographic Unit Cell

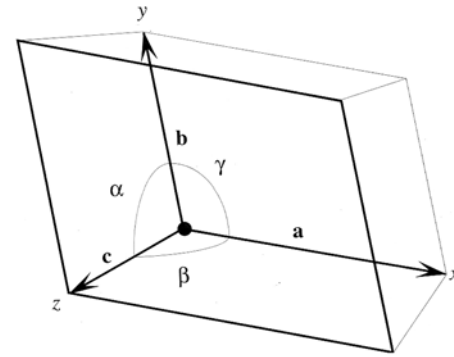

Parallelepiped volume defined by 3 unique edges ( $a, b, c$ ) and 3 angles ( $\alpha, \beta, \gamma$ ).

Contains 1 or more protein molecules, depending on crystallographic symmetry.

Asymmetric unit is a fraction of the unit cell volume that can generate the full contents of the unit cell by application of crystallographic symmetry operators.

For example, a 2-fold rotational symmetry operator applied to the a.s.u. in space group P2 generates the other half of the unit cell.

# Crystal Classification

Triclinic:  $(a \neq b \neq c), (\alpha \neq \beta \neq \gamma)$  –no internal crystallographic symmetry.

Monoclinic:  $(a \neq b \neq c), (\alpha = \gamma = 90^\circ; \beta \neq 90^\circ)$

Hexagonal:  $(a = b), (\alpha = \beta = 90^\circ; \gamma = 120^\circ)$

For unit cells with  $(\alpha = \beta = \gamma = 90^\circ)$ :

Cubic:  $(a = b = c)$

Tetragonal:  $(a = b \neq c)$

Orthorhombic:  $(a \neq b \neq c)$

# Crystal Symmetry

The symmetry of a unit cell is described by the space group, represented by a symbol (e.g.,  $P2_12_12_1$ ).

The space group symbol designates the type of lattice (P,I,C, etc.) followed by rotational and translational symmetry.

A complete description of space group properties is found in the International Tables for Crystallography.

- <http://www.iucr.org/iucr-top/it/index.html>

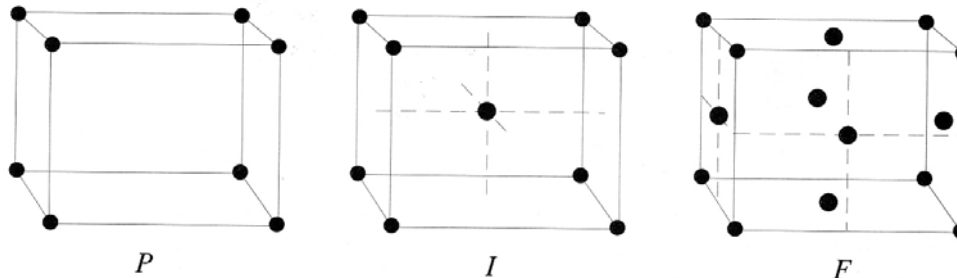

# Diffraction by a Crystal

von Laue condition for diffraction by a 1-dimensional crystal (vertical row of atoms):

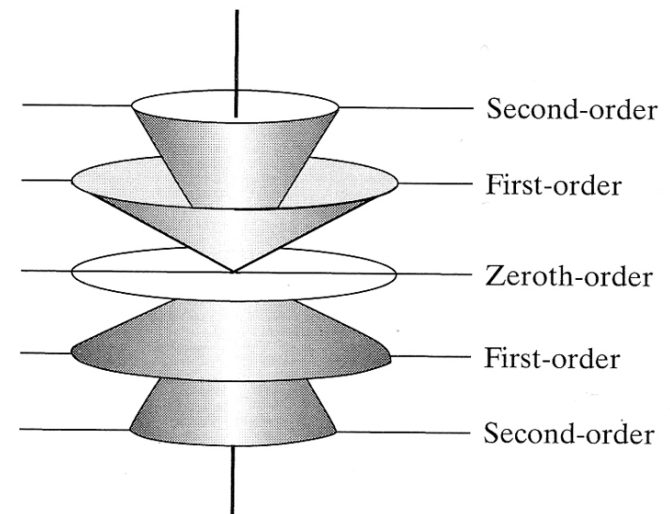
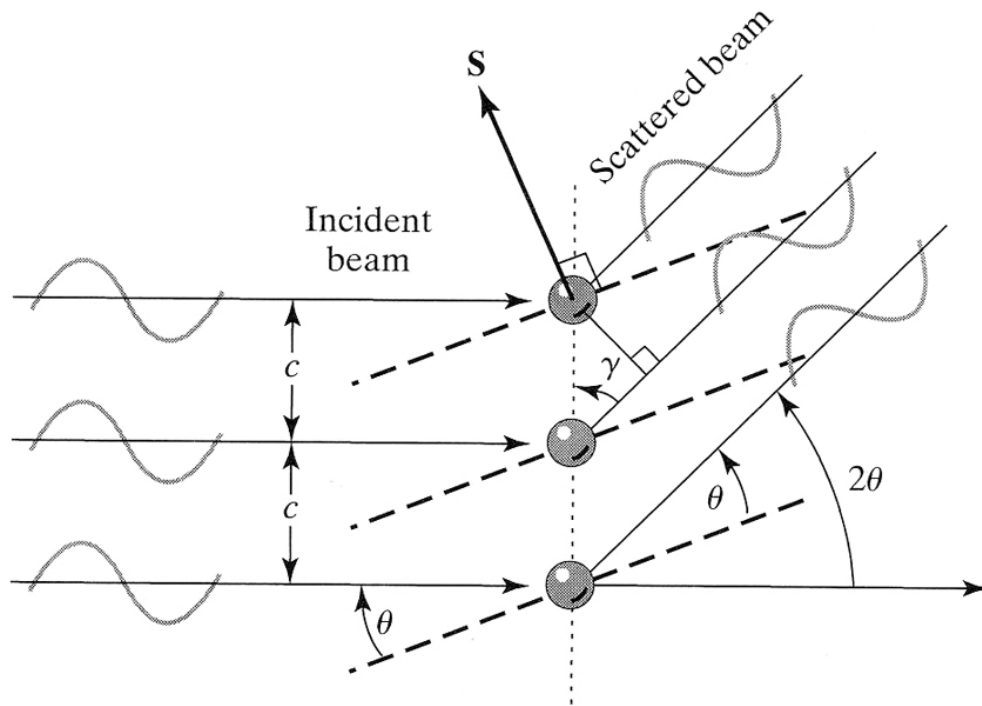

# Constructive Interference in a Crystal

Define sets of parallel planes in a crystal so that all “corresponding atoms” scatter with a phase offset of zero.

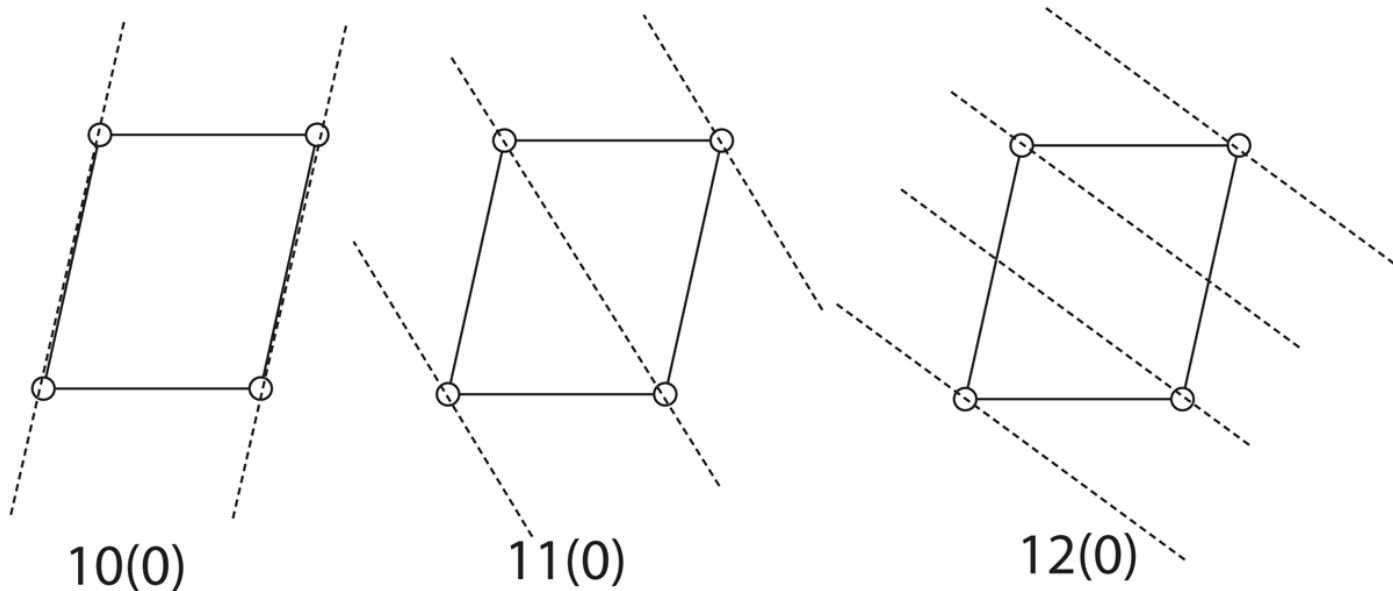

# Crystal (Miller) Indices

Atomic planes in the crystal are specified by indices  $(h,k,l)$  corresponding to  $h=1/n_a$  where  $n_a$  is the number of times the  $a$ -axis is divided, etc.

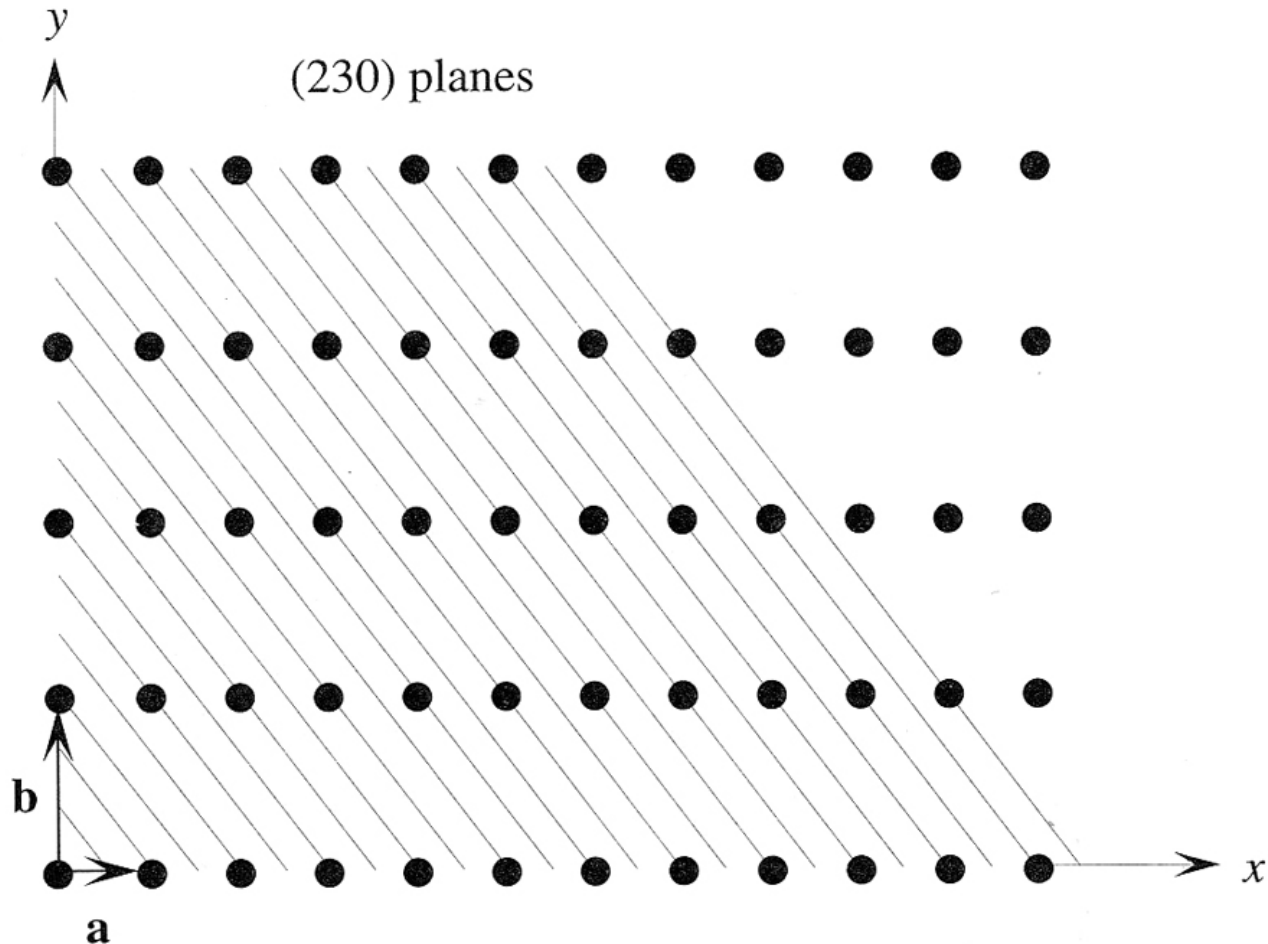

# More Miller Indices

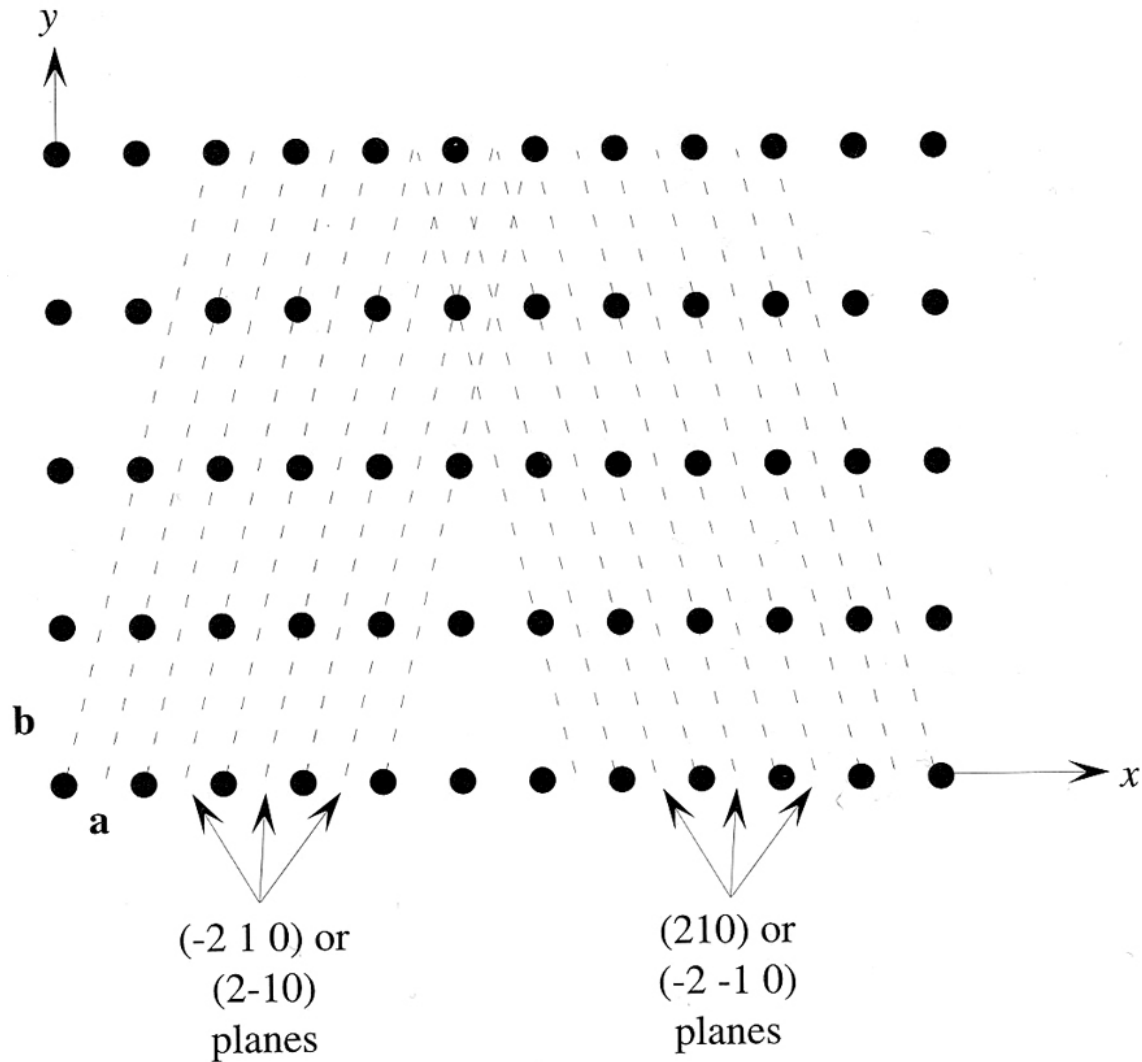



# Construction of the Reciprocal Lattice

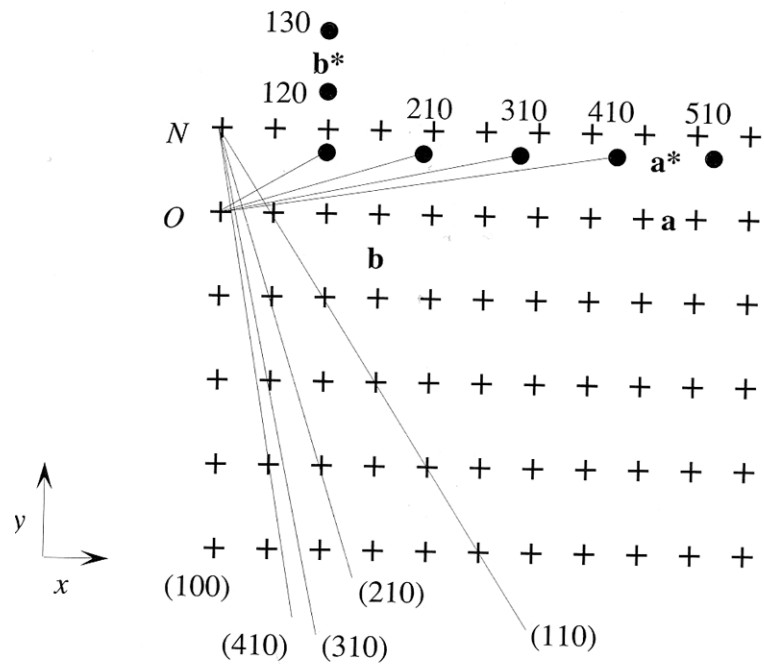
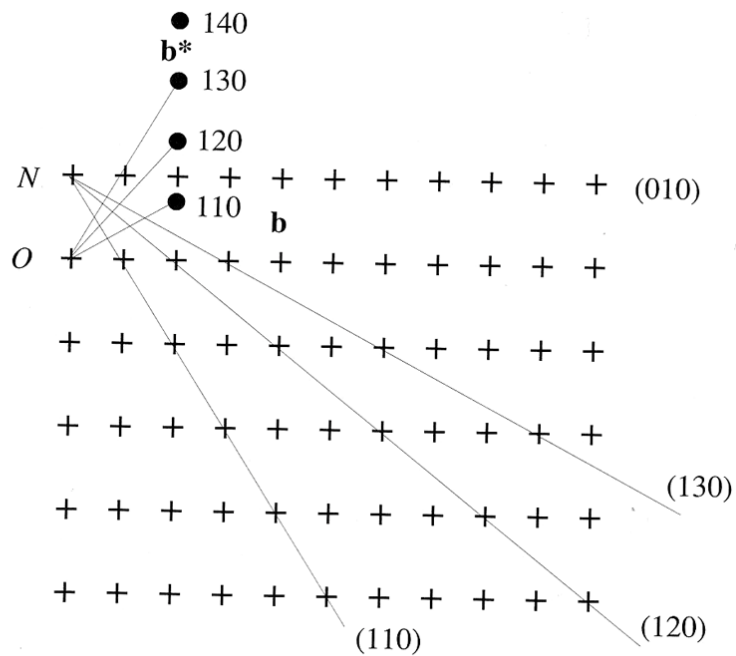

# Reciprocal vs. Real Unit Cells

Reciprocal  
unit cell

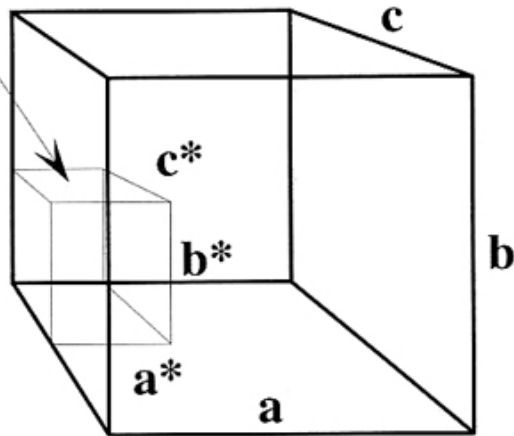

Real unit cell

Real unit cell

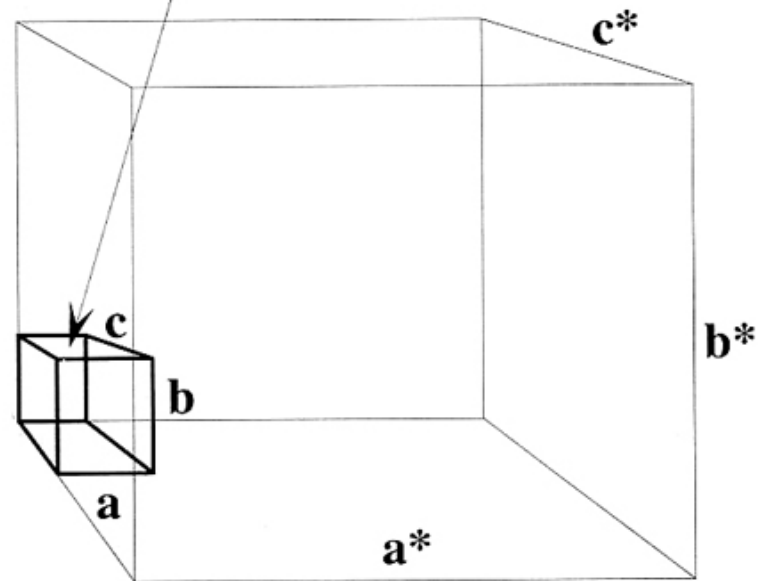

Reciprocal unit cell

# The Reciprocal Lattice

Each possible way of drawing planes through the unit cell (dividing each cell axis into an integral number of pieces) corresponds to one reciprocal lattice point (h,k,l).

For an orthorhombic cell:  $a^* = 1/a$   $b^* = 1/b$   $c^* = 1/c$

Directions:  $a^* = b \times c$   $b^* = c \times a$   $c^* = a \times b$

$$a = b^* \times c^* \quad b = c^* \times a^* \quad c = a^* \times b^*$$

Distance:  $d^{*2} = h^2 a^{*2} + k^2 b^{*2} + l^2 c^{*2} + \dots$

# International Tables for Crystallography

Lists equivalent positions for the 230 space groups, such as the primitive monoclinic space group  $P2_1$ :

$P2_1$   
 $C_2^2$

No. 4

$P 1 1 2_1$

2 Monoclinic

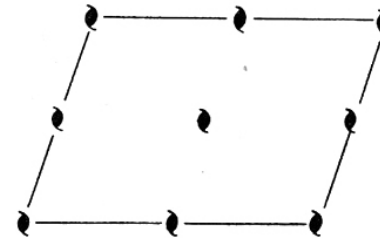
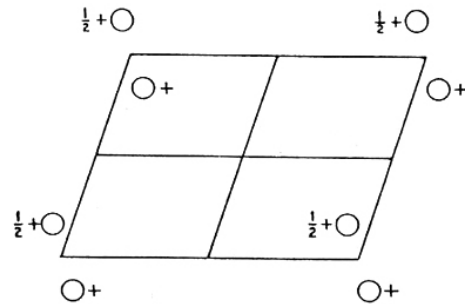

1st SETTING

Origin on  $2_1$ ; unique axis  $c$

Number of positions,  
Wyckoff notation  
and point symmetry

Co-ordinates of equivalent positions

Conditions limiting  
possible reflections

2     $a$     1     $x, y, z; \bar{x}, \bar{y}, \frac{1}{2} + z.$

$hkl$ : No conditions  
 $hk0$ : No conditions  
 $00l$ :  $l=2n$

# Diffraction by a Crystal

Fourier series  $\tilde{F} = \int \rho e^{ihx} = \sum_j^{atoms} e^{ihx}$

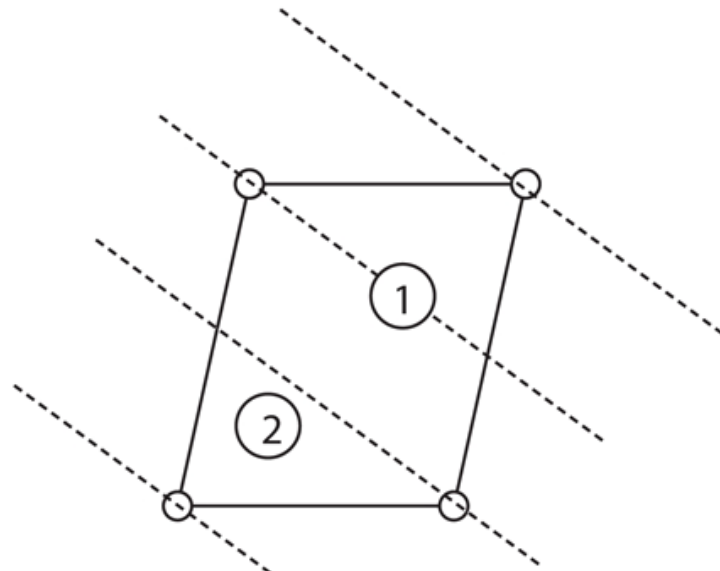

$$\tilde{F}_{12(0)}$$

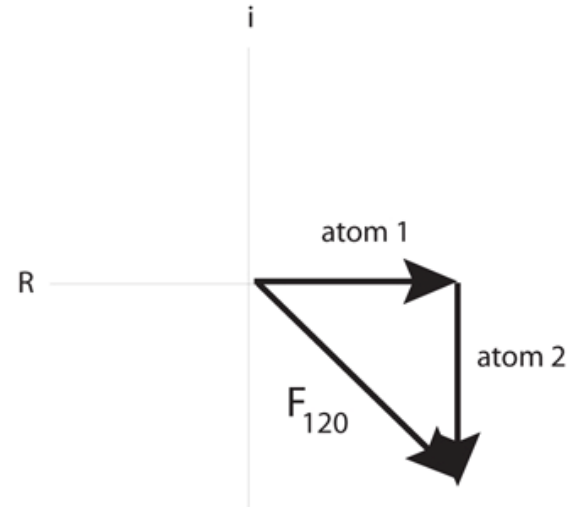

# Structure-dependent Variation in Intensities

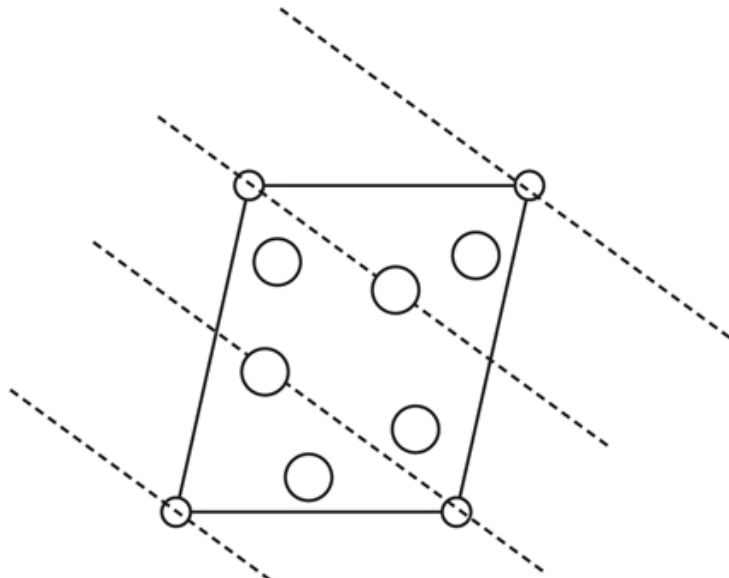

weak reflection

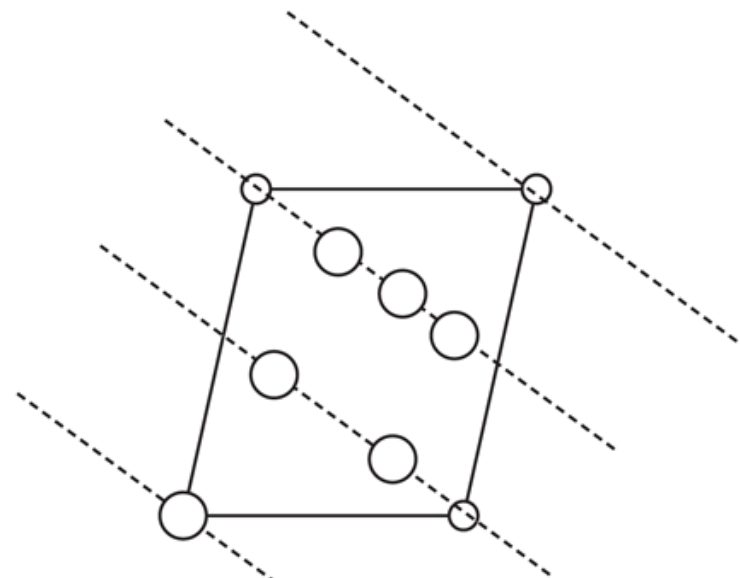

strong reflection

# Reflecting Condition

Reciprocal lattice point at distance  $1/d=d^*$  from origin.

Bragg diffraction condition satisfied when lattice point has been rotated onto the surface of the sphere:

$$2\left(\frac{1}{\lambda} \sin \theta\right) = \frac{1}{d} = d^*$$

